

## 515B Dress •• by burdafashion.com – Instructions

**Burda sizes 34, 36, 38, 40, 42, 44**  
Length from waist: 112 cm (44")

### Materials:

Silk voile, 135 cm (53") wide, with 95 cm (37½") pattern repeat: 4.75 m (5¼ yds) (= 5x pattern repeat) for all sizes.

**Please note:** If you use a fabric with no pattern repeat, you will need 3.05 m (3¾ yds) of 135 cm (53") wide fabric.

Chiffon as lining, 150 cm (59") wide: 3.00 m (3¾ yds).

1 invisible zipper, 40 cm (16") long, and special presser foot. Elastic thread (for smocking). Buttonhole elastic, 1.2 cm (½") wide:

sizes 34, 36: 80 cm (32"); size 38: 85 cm (34"); size 40: 90 cm (36"); sizes 42, 44: 95 cm (38"). 1 flat button. Sewing thread

**Recommended fabric:** Lightweight, flowing dress fabrics.

### Printing paper pattern (for DIN A / 8¼" x 11½" paper):

The pattern pieces are printed on 45 sheets, each framed by a thin line. Wait until all of the sheets have been printed. Lay the sheets in the correct positions (see extra sheet with the overview of the printed sheets).

Cut each sheet along the thin lines at the top and right edges. Beginning with the lower left sheet, glue all sheets together, exactly on the thin lines.

**Important:** Seam and hem allowances are not included on the pattern pieces.

### Paper pattern:

Choose your size according to the Burda measurement chart: dresses, blouses, jackets, and coats according to your bust measurement and pants and skirts

### Cutting layouts

Sizes 34 to 44

Silk voile, 135 cm wide

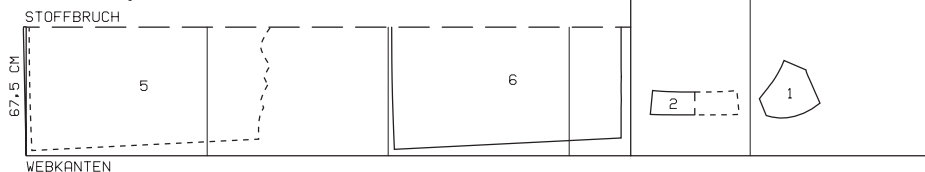

Lining chiffon, 150 cm wide

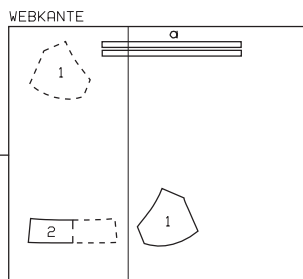
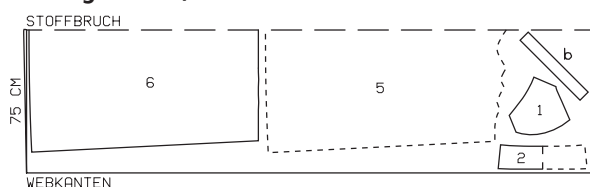

*Right side faces in on a double layer of fabric and faces up on a single layer. Cut right and left bodice fronts as mirror images.*

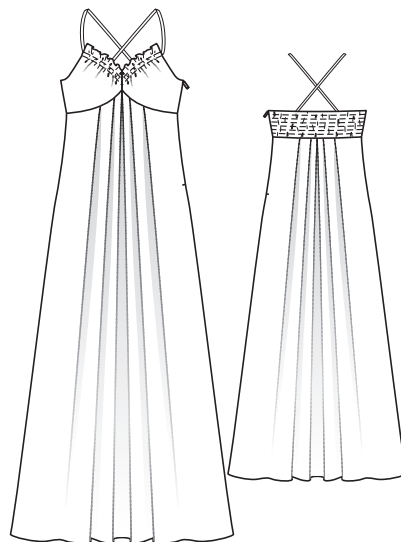

### Pattern pieces 1, 2, 5, and 6

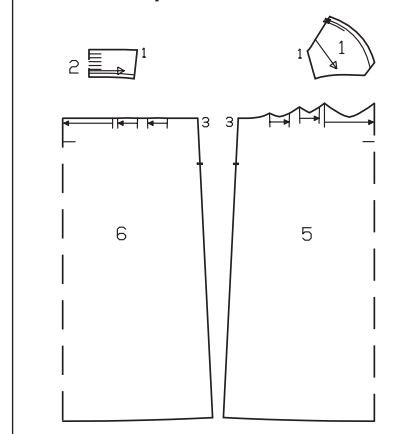

according to your hip measurement.

Adjust pattern pieces, if necessary, by adding or subtracting the cm (inches) that your measurements differ from the measurements given in the Burda chart.

The stitching lines for casing marked on pattern piece 1 apply for size 34. For all remaining sizes, mark stitching lines the same distance from corresponding size line. Stitching lines for elastic smocking (piece 2) will be marked directly on the fabric (see "Bodice back piece").

### Cutting:

The cutting layout below shows how the pattern pieces should be laid on the fabric. Make sure that the straight grain line marked on each pattern piece lies parallel to the selvages or the fold of the fabric.

### Seam and hem allowances:

Use a ruler and tailor's chalk to mark seam and hem allowances on the fabric, along edges of the paper pattern pieces: 1.5 cm (¾") at all seams and edges.

### Silk voile

1 Bodice front	2x
2 Bodice back, on fold	1x
5 Skirt front, on fold	1x
6 Skirt back, on fold	1x
a) 2 straps, each to following length, for sizes 34, 36: 65 cm (26"); sizes 38, 40: 70 cm (28"); sizes 42, 44: 75 cm (30"); all 3 cm (1¼") wide (incl. allowances).	

### Transfer pattern markings to fabric pieces:

Transfer all pattern outlines (seam and hem lines) and pattern lines and markings (except grain lines) to wrong side of fabric pieces using a tracing wheel and BURDA dressmaker's carbon paper. Follow manufacturer's instructions. Hand baste along stitching lines for casing on piece 1 to make these lines visible on right side of fabric.

**Important:** First test the carbon paper and tracing wheel on a scrap of your fabric. If the lines are also visible on the right side of the fabric, then you should use "tailor tacks" instead. To make tailor tacks, use doubled sewing thread to hand-baste along the edges of the pattern piece, leaving a loop of thread, approx. 2 cm (¾") high, after each stitch. Cut each loop. Pull the fabric layers apart and carefully clip the threads between the layers of fabric. The thread pieces which remain in the fabric serve as the pattern markings.

## Lining chiffon

1 Front	2x
2 Back, on fold	1x
5 Skirt front, on fold	1x
6 Skirt back, on fold	1x
b) Bias strip for back neck edge, to the following length for	
size 34: 43 cm (17"); size 36: 45 cm (17½");	
size 38: 47 cm (18½"); size 40: 49 cm (19¼");	
size 42: 51 cm (20¼"); size 44: 53 cm (21"),	
all 6 cm (2½") wide (incl. allowances).	

## Sewing:

**Please note:** When basting and stitching seams, the right fabric sides must be facing. Tie-off the beginnings and ends of seams with backstitching.

■ **Straps:** Fold each fabric strip in half lengthwise, right side facing in. Stitch 7 mm (¼") from fold edge. Do not cut thread ends too short. Thread through eye of darning needle and push needle through fabric tube, eye end first, to turn right side out. Press straps.

■ **Front:** Lay bodice lining fronts on voile bodice front pieces, right sides facing. Pin together along upper front and upper side edges. Stitch along these edges, on upper side edges interrupting stitching between slit marks. Trim seam allowances. Turn bodice front units right side out. Press. Stitch along upper front edges with closely spaced zigzag stitching. Topstitch upper front edge as marked to form casing. Baste fabric layers together along side and lower edges. Pull straps into casings and pin ends to seam allowances on center front seam edges. Lay front units together, right sides facing. Stitch center front seam, beginning exactly at marked skirt attachment seam and catching strap ends in seam. Press seam open. Finish edges of allowances.

■ **Bodice back piece:** Lay bodice lining back piece on outer bodice back piece, wrong sides facing. Baste together along all edges.

For the elastic smocking, use vanishing marker to first draw the stitching lines on the lining side of the back, as follows:  
**Sizes 34, 36:** Mark the lowest line 1.5 cm (⅝") above the marked attachment seam, then mark 4 more lines, each spaced 1.5 cm (⅝") apart;

**Sizes 38, 40:** Mark the lowest line 1.6 cm (⅝") above the marked attachment seam, then mark 4 more lines, each spaced 1.6 cm (⅝") apart;

**Sizes 42, 44:** Mark the lowest line 1.7 cm (⅞") above the marked attachment seam, then mark 4 more lines, each spaced 1.7 cm (⅞") apart.

Cut 5 pieces of elastic thread, each approx. 10 cm (4") longer than width of bodice back piece. Lay one piece of elastic thread on each marked line and stitch over thread with zigzag stitching, beginning and ending exactly at marked side seam lines. The zigzag stitching must be wide enough that the elastic

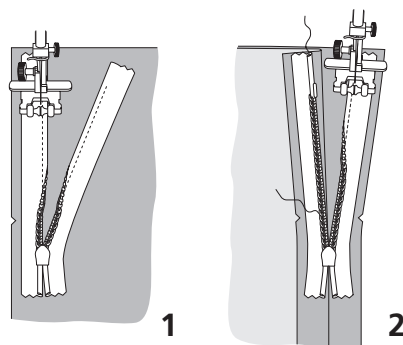

thread is not caught by the stitching.

■ **Right side seam:** Lay bodice front on bodice back, right sides facing. Pin right side seam – the allowance on upper back edge extends above upper edge of front. Stitch right side seam, making sure to not catch elastic threads. Trim allowances to 1 cm (⅜") wide, finish edges together, and press toward back.

■ **Skirt:** Lay skirt front of voile on skirt back of voile, right sides facing. Stitch right side seam. Trim allowances to 7 mm (¼") wide, finish edges together, and press toward skirt back. Stitch right side seam on skirt lining in same manner.

Lay voile skirt unit on skirt lining unit with right sides of both facing up. Baste together along upper edge and along side edges, to length of slit. Working from outer (voile) side, lay pleats in upper edge of skirt in direction of arrows – first side pleats, then center pleat (= reversed pleat) – and baste.

Pin upper edge of skirt to lower edge of bodice, right sides facing. Stitch. Trim seam allowances to 1 cm (⅜") wide, finish edges together, and press up.

■ **Invisible zipper, left side seam:** Finish edges of allowances on left side seam edges – finishing edges together above slit mark and finishing edges separately below slit mark. Open the zipper and push the coil back with your thumbnail to reveal the seam line between the tape and the coil. Place the open zipper face down on the right fabric side of the back slit edge, so that the zipper teeth begin at the marked neck edge. In order to stitch the zipper exactly in place along the marked seam line, the distance between the tape edge and fabric edge must first be calculated: 1.5 cm (⅝") wide seam allowance minus 1 cm (⅜") tape width = 5 mm (¼") distance from fabric edge. Pin upper end of zipper tape in place, 5 mm (¼") from edge of seam allowance. The bottom end of the zipper will extend past the marked end of the slit. Place the presser foot on the zipper so that the coil lies in the notch to the right of the needle (1). Stitch zipper in place from the top to the marked end of the slit, making sure to not catch elastic threads. Close the zipper. Place the second zipper tape face down on the right fabric side of the front slit edge and pin in

place (distance from edge of allowance = 5 mm/¼"). Open zipper again. Place the presser foot on the top end of the zipper so that the coil is in the notch to the left of the needle (2). Sew the zipper in place from the top to the end of the slit.

Close zipper. Clip allowance of chiffon (outer) skirt at end of zipper, close to zipper stitching lines. First pin side seam on skirt lining below zipper (right sides of fabric are facing), turning loose end of zipper out of way, over seam allowance. Stitch seam, beginning on lower edge and stitching as close to last stitches of zipper seams as possible. Then stitch side seam on chiffon skirt from lower edge to clip. Press seams open.

Hand-sew a thread bar on the zipper, approx. 1 cm (⅜") below the slit end, then trim away excess end of zipper, approx. 3 cm (1¼") below the thread bar. Cut a piece of fabric, approx. 4 x 4 cm (1½" x 1½"), fold it in half, lay it over end of zipper, and sew in place.

On front slit edge, turn upper end of zipper to inside and sew in place.

■ **Upper back, casing for elastic:** Fold bias strip in half lengthwise, right side facing out. Press. Pin strip to upper back edge so that the fold edge lies on body of back piece, 2 cm (¾") past seam line, and open edges lie on allowance. Turn ends of bias strip to outside, over right side seam and 5 mm (⅜") before zipper slit, and pin in place. Fold slit allowance with zipper to outside and pin to upper back edge, over bias strip. Stitch upper back edge to bias strip. Trim seam allowances. Turn slit allowances and bias strip to inside. Stitch along upper back edge with closely spaced zigzag stitching. To form casing for the elastic, topstitch the upper back edge exactly half-way between the upper edge and the upper stitching line of elastic smocking, thereby catching the bias strip.

Pull the elastic threads to create the "smocked" effect, pulling threads until bodice back is the following width, for size 34: 28 cm (11"); size 36: 30 cm (12"); size 38: 32 cm (12¾"); size 40: 34 cm (13½"); size 42: 36 cm (14¼"); size 44: 38 cm (15").

Pull buttonhole elastic into casing on upper back edge. Sew button to one end of elastic.

Try dress on. Button elastic closed on front of dress, below the bust, to fit. Adjust elastic smocking, if needed, and knot ends of elastic threads securely. Cross straps over back, pin ends to upper back edge, and sew in place.

■ **Press hem allowances on voile skirt and skirt lining to inside, separately.** Stitch along fold edges with closely spaced zigzag stitching. Carefully trim hem allowances next to stitching.

# BURDA SIZE TABLE

<b>WOMEN'S SIZES</b> (height 168 cm/ 5 feet 6 inches)											
Burda size		34	36	38	40	42	44	46	48	50	52
Bust	cm	80	84	88	92	96	100	104	110	116	122
Waist	cm	62	66	70	74	78	82	86	92	98	104
Hip	cm	86	90	94	98	102	106	110	116	122	128
Front waist length	cm	43	44	45	46	47	48	49	50	51	52
Bust depth	cm	25	26	27	28	29	30	31	32	33	34
Back length	cm	41	41	42	42	43	43	44	44	45	45
Back width	cm	33.5	34.5	35.5	36.5	37.5	38.5	39.5	41	42.5	44
Shoulder	cm	12	12	12	13	13	13	13	14	14	14
Arm length	cm	59	59	60	60	61	61	61	61	62	62
Upper arm	cm	26	27	28	29	30	31	32	34	36	38
Neck	cm	34	35	36	37	38	39	40	41	42	43